



## Model 100B–250 B&P Speedmullor® Direct Drive Upgrade (Conversion Kit)

### Bulletin Number

#2003002v2

### Affected Products

Beardsley & Piper Model  
100B–250 Speedmullor®

### Affected Parts

Part numbers:

- Complete 250 horsepower drive assembly including gearbox, motor, rails, belts, sheaves and guards

### Revision Date

September 13, 2004

### The Issues

The direct drive conversion kit was designed to simplify installation, significantly increase the useful life of the gearbox and greatly reduce the drive maintenance by eliminating belts and sheaves.

### The Solution

The original 100B–250 drive design required separate mounting for the gearbox, motor, guards, and oil cooler. This design also required aligning sheaves and belts and regular maintenance to control belt tension, locating and mounting oil cooler and external piping between oil cooler and gearbox. The new direct drive has been designed as a complete unit, fully assembled and tested, to replace all components of the original drive design. No adapter or mounting brackets are required for installation of the new drive onto an existing Speedmullor. Furthermore, since the motor is mounted at our facilities, no alignment or adjustments are required during installation. The new drive utilizes the same mounting holes as the original drive to help simplify the installation process. The gearbox's central lubrication (oil cooler) assembly is an integral part of the new drive and it does not require separate mounting or external piping. The new drive design has been engineered to have a smaller foot print which requires no additional room for installation.

The direct drive gearbox has been designed with a service factor 25% higher than the original design. All gearing has been carburized, hardened and ground to AGMA quality 12. The new direct drive comes with a 36 month warranty.

The direct drive replaces all components of the original drive and consists of:

- New design gearbox
- 250HP, 1800 rpm, 440V, 60Hz, 1.15 SF, 449 TC frame electric motor
- Base motor mounting
- Coupling guard
- Gearbox central lubrication (completely assembled, piped, wired and mounted to the side of the motor mounting base) consisting of:
  - ½ HP motor, coupling and pump

- Heat exchanger (water to oil) and temperature switch
- Filter, flow switch and strainer with magnet
- Relief valve, check valve and pressure gauge
- Visual flow indicators
- Control cabinet with disconnect, transformer, starter, push buttons and lights

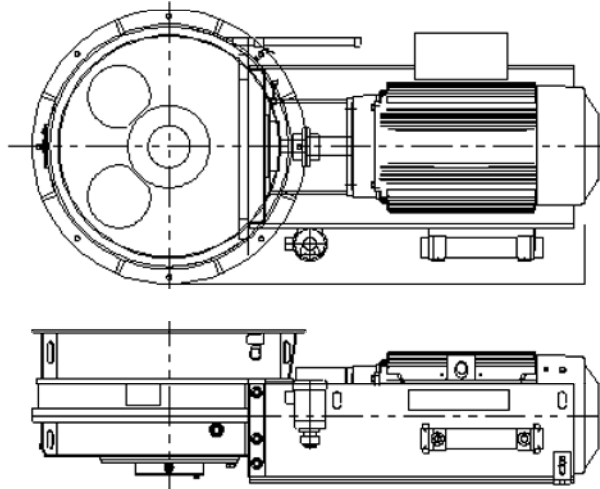

**Direct Drive Unit Schematic**

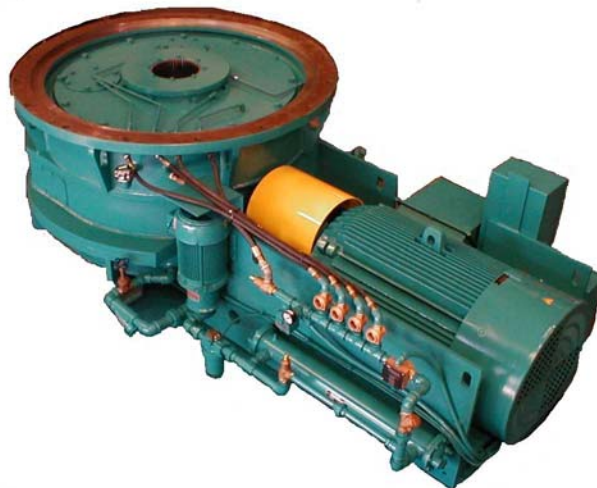

**Direct Drive Unit Photo**

To order the upgrade kit, please contact Simpson by phone (630-978-0044), fax (630-978-0068) or email ([parts@simpsongroup.com](mailto:parts@simpsongroup.com)).

## SIMPSON GROUP

Founded in 1912, Simpson Technologies is a world leader in foundry and process industry technologies. Within the Simpson Group are some of the world's largest and most innovative brands of metal casting technologies including the companies Simpson Technologies, Beardsley & Piper LLC, Hartley Controls Corp. as well as the brands of Dietert Automation and Simpson+Gerosa. In the metal casting industries our products include technologies in the following areas:

- Molding Sand Cooling
- Molding Sand Preparation (batch & continuous)
- On-line Controls for Sand Preparation Systems
- Flaskless, Matchplate Mold Making Equipment
- Core Sand Preparation Equipment
- Core Making Equipment
- Sand Reclamation Equipment
- Pollution Control Equipment
- Sand Laboratory Testing Instrumentation
- OEM Spare Parts and Field Service
- Laboratory Testing and Rental Equipment



751 Shoreline Drive  
Aurora, IL 60504 USA  
Tel: +1 (630) 978-0044  
Fax: +1 (630) 978-0068

Email: [sales@simpsongroup.com](mailto:sales@simpsongroup.com)

Web: [www.simpsongroup.com](http://www.simpsongroup.com)

To find a representative near you, go to: <http://www.simpsongroup.com/contacts/contacts.htm>

